

VALVCHEQ BACKFLOW PREVENTERS

FIGURE DC03

Double check valves for medium hazard rated applications
Flanged and roll grooved end connections



FEATURES

- Compact simple design.
- In-line and on-site serviceable.
- No special tools required for servicing.
- Lifting lugs to assist with installation.
- Designed and manufactured in accordance with AS/NZS 2845.1.
- FBE coated to AS/NZS 4158.
- Straight through flow path for maximum flow co-efficient.
- Top entry allows all parts to be accessed easily.
- Stainless steel internals for superior corrosion resistance.
- Fully restrained check valve assemblies for unrivalled safety.
- Ductile Iron body for high strength and impact resistance.
- Every valve is bench tested and tracked with unique serial number.
- All internal components are repairable or replaceable.
- All internal and external bolting is stainless steel.
- Conforms to testing requirements of AS/NZS 2845.3.
- Anti-tamper test taps.
- Design conforms to all major international standards.
- Installations can be vertical and horizontal.

GENERAL APPLICATION

The DC03 provides protection from both backsiphonage and backpressure of the potable water supply from contamination in medium hazard applications.

TECHNICAL DATA

Size range: DN 65 - 150
 Temperature rating: 1 °C to 60 °C
 Working pressure: PN16
 End connections: Flanged AS 4087
 Roll grooved AS 2638
 Alternative flange drillings may be available on request



AS/NZS 2845.1 Lic WMKA 1324
SAI Global

VALVCHQ BACKFLOW PREVENTERS

FIGURE DC03

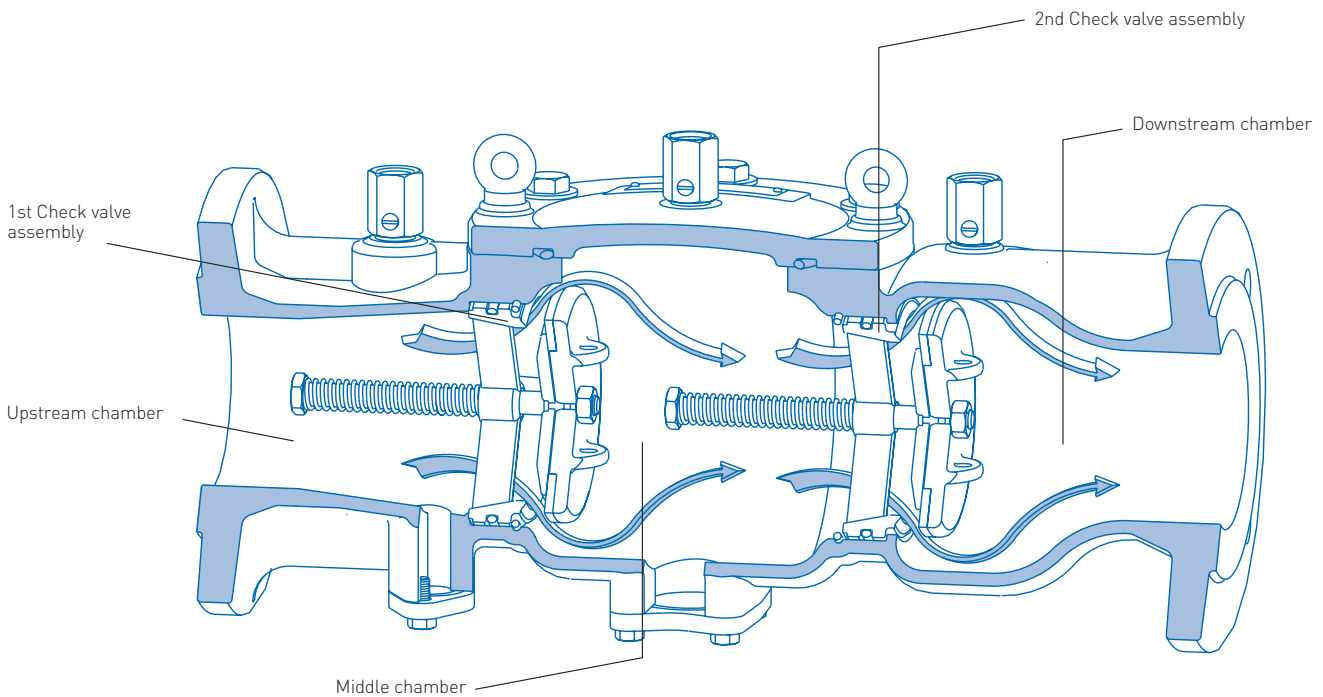

PRINCIPLE OF OPERATION

Double check valve consists of two independently acting non-return valves in series. They are arranged to be force-loaded in the closed position.

Under dynamic flow conditions:

Water enters upstream chamber before the 1st check valves assembly. When water pressure is sufficient (minimum of 7 kPa) 1st check valve assembly will open allowing flow into and fill the middle chamber.

Once the middle chamber is full and pressurized (minimum of 7 kPa), the 2nd check valve assembly will open allowing flow though the down stream chamber.

Under the condition of backpressure:

(Premises pressure is greater than supply pressure)

Water pressure in down stream chamber and spring pressure force the 2nd check valve assembly closed.

Under the condition of backsiphonage:

(Negative/low supply pressure in mains supply)

Water pressure in the up stream chamber before the 1st check valve assembly will dissipate and 1st check valve assembly will close under spring pressure.

VALVCEQ BACKFLOW PREVENTERS

FIGURE DC03

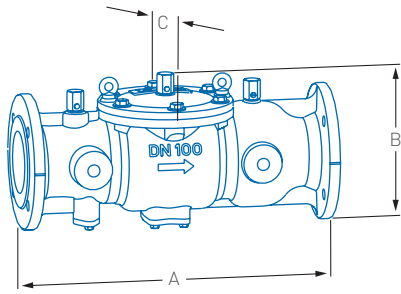

Note: valve only (VO) illustrated.

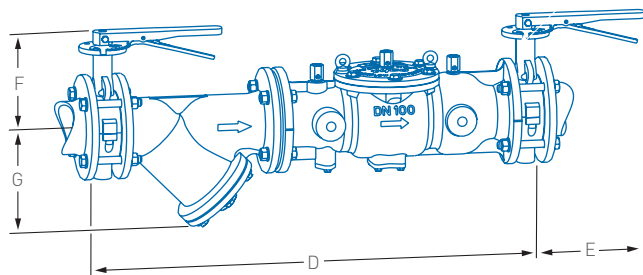

Note: butterfly valve (BFV) arrangement illustrated.

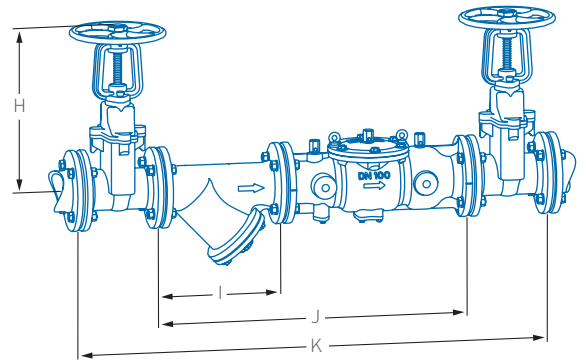

Note: resilient seated gate (RSGV) valve arrangement illustrated.

DIMENSIONS (mm)

Valve size DN	A	B	C	D	E	F	G	H	I	J	K	Mass (kg)		
												VO	BFV	RSGV
65	400	335	185	767	240	180	177	-	273	675	-	21	40	-
80	400	335	185	786	240	190	210	367	292	694	1103	21	47	70
100	535	382	230	993	240	210	235	402	352	889	1350	38	79	139
150	685	480	300	1269	240	230	390	502	470	1157	1694	76	144	228

NOTE

Dimension are nominal to ± 1 mm.

Butterfly valve actuators change from handles to gear operators on valve sizes 150 mm and above.

Gear operation actuators available on request for butterfly valve arrangement.

Lockable actuators available on request.

VO = Mass of valve only.

BFV = Mass of complete arrangement with butterfly valves.

RSGV = Mass of complete arrangement with resilient seated gate valves.

VALVCHQ BACKFLOW PREVENTERS

FIGURE DC03

TYPICAL FLOW CHARACTERISTIC GRAPHS

DN 65 valves

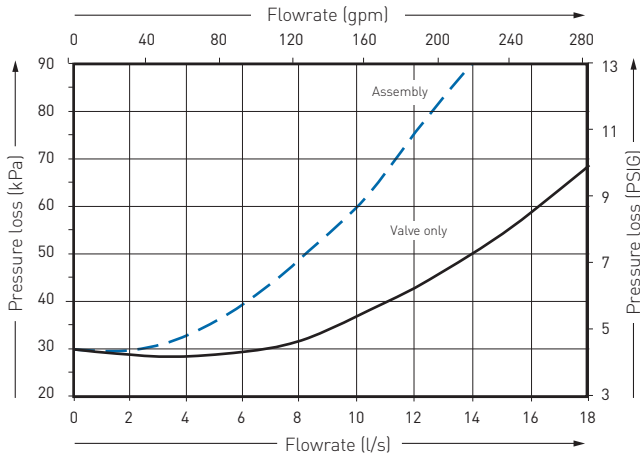

DN 80 valves

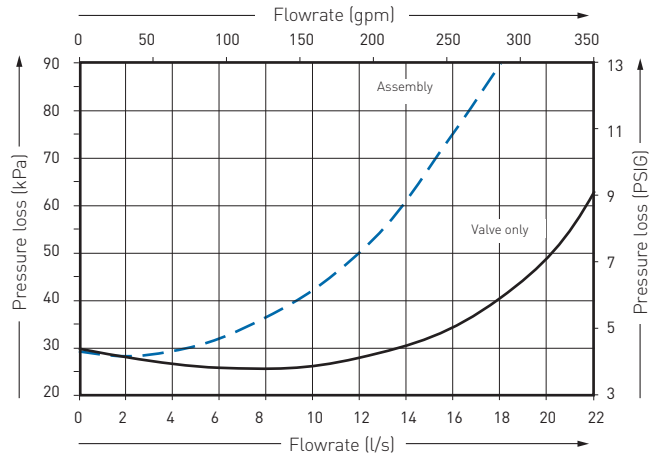

DN 100 valves

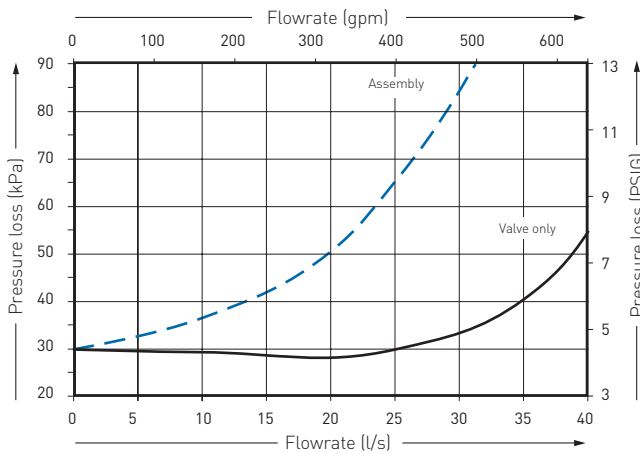

DN 150 valves

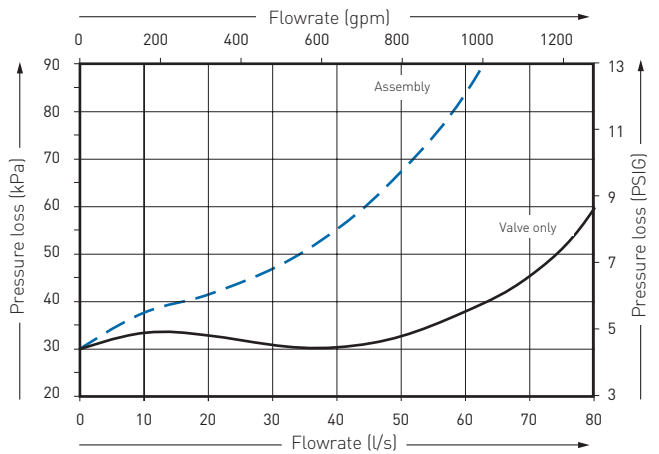

NOTE

- — — Complete valve assembly
- — — Valve only

VALVCEQ BACKFLOW PREVENTERS

FIGURE DC03

SELECTION GUIDE

Example:	100	DC03	C	CO	BF
Valve size (DN)					
Figure no.					
End connections					
C	Flanged AS 4087				
R/G	Roll grooved AS 2368				
	Alternative flange drillings may be available on request				
Assembly					
VO	Valve only				
CO	Complete with isolation valves and FBE coated strainer				
FS	Fire service (supplied without strainer)				
Isolation					
BF	Butterfly valves				
BF G/Op	Butterfly valves gear actuated				
BF G/Op L	Butterfly valves gear actuated lockable				
RSGV	Resilient seating gate valves				

NOTE

All Emerson isolation valves come with the provision for locking.

TROUBLESHOOTING

Symptom	Cause	Remedy
1st check valve not holding tight (reading approaches zero without holding)	<ol style="list-style-type: none"> 1. Debris fouling the check valve seal 2. Check valve seal damaged or perished 3. Check valve O-ring damaged 4. Check valve stem O-ring damaged 5. Check valve seal ring damaged 	<ol style="list-style-type: none"> 1. Inspect, clean, reverse or replace check seal 2. Inspect and replace check valve seal 3. Inspect and replace O-ring 4. Inspect and replace O-ring 5. Replace first check valve assembly
1st check valve holding below 7 kPa	<ol style="list-style-type: none"> 1. Debris fouling the check valve seal 2. Check valve seal damaged 3. Check valve spring memory loss or damaged 4. Check valve stem O-ring damaged 	<ol style="list-style-type: none"> 1. Inspect, clean, reverse or replace check seal 2. Inspect and replace check valve seal 3. Replace first check valve assembly 4. Inspect and replace O-ring
2nd check valve not holding tight (reading approaches zero without holding)	<ol style="list-style-type: none"> 1. Debris fouling the check valve seal 2. Check valve seal damaged or perished 3. Check valve O-ring damaged 4. Check valve stem O-ring damaged 5. Check valve seal ring damaged 	<ol style="list-style-type: none"> 1. Inspect and clean, reverse or replace check seal 2. Inspect and replace check valve seal 3. Inspect and replace O-ring 4. Inspect and replace O-ring 5. Replace second check valve assembly
2nd check valve holding below 7 kPa	<ol style="list-style-type: none"> 1. Debris fouling the check valve seal 2. Check valve seal damaged 3. Check valve spring memory loss or damaged 4. Check valve stem O-ring damaged 	<ol style="list-style-type: none"> 1. Inspect, clean, reverse or replace check seal 2. Inspect and replace check valve seal 3. Replace second check valve assembly 4. Inspect and replace O-ring

VALVCHEQ BACKFLOW PREVENTERS

FIGURE DC03

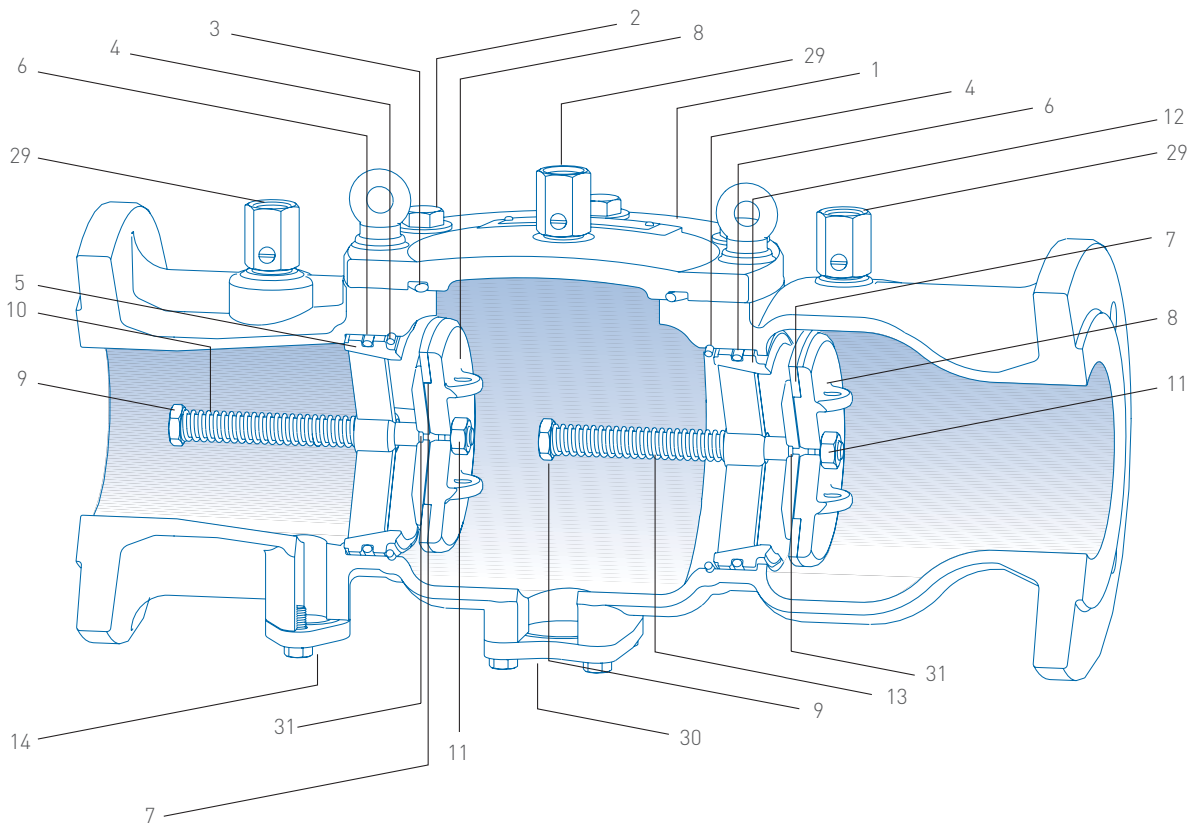

PARTS LIST

No.	Description
1	Cover plate
2	Cover plate bolts
3	Cover plate O-ring
4	Check valve circlip
5	1st check valve seal ring
6	Check valve O-ring
7	Check valve seal
8	Check valve disc
9	Check valve stem
10	1st check valve spring
11	Check valve retaining nut
12	2nd check valve seal ring
13	2nd check valve spring
14	Sensor port plate
29	Test taps
30	Relief port plate
31	Check valve stem O-ring

VALVCHQ BACKFLOW PREVENTERS

FIGURE DC03

Complete safety and maintenance instructions for DN 65 to DN 150 medium hazard devices

MAINTENANCE AND TESTING REQUIREMENTS

Test after initial installation and annually for the life of the valve or service. Maintain in a working order and inspect for operational function at intervals not exceeding twelve months. The functions are to be carried out by authorized licensed backflow testers.

DISASSEMBLY INSTRUCTIONS

As per safety precautions slowly close isolation valves and then open all three test taps (29) to drain relief port.

Remove cover plate bolts (2) and washers.

Remove cover plate (1) and cover plate O-ring (3).

With screwdriver remove 2nd check valve assembly circlip (4) utilizing cavity recess in the body casting.

NOTE

Please take care not to damage FBE coating with screwdriver.

To remove 2nd check valve assembly pull check valve stem (9) out and then up bringing the check assembly through the top entry of the valve.

With screwdriver remove 1st check valve assembly circlip (4) utilizing cavity recess in the body casting.

NOTE

Please take care not to damage FBE coating with screwdriver.

To remove 1st check valve assembly take a screwdriver and lever the assembly out by utilizing lug provided on check valve disc (8). Or slowly crack open inlet isolating valve and allow the water pressure to push the check valve assembly into the main valve body. Shut-off isolating valve and remove check valve assembly through top entry of valve.

Both check valve assemblies are mechanically the same, so the same procedure can be used for both assemblies. Fit spanner to the check valve stem head (9) and to the check valve retaining nut (11) turn retaining nut anti-clockwise and remove.

Remove check valve disc (8) to expose check valve seal (7) for servicing or replacement.

NOTE

When assembly takes place all components:

- Lubricate all O-rings.
- Check valve seal (7) must be clean, free of any greases, moisture and debris upon assembly for a positive seal.

SAFETY PRECAUTIONS

In every instance of installation or removal from the pipeline, ensure the line is not pressurized and any hazardous liquid is drained away. Slowly close both isolating valves and then open test taps (29) to exhausted line pressure.

VALVCHEQ BACKFLOW PREVENTERS

FIGURE DC03

Recommended specifications for double check valves for medium hazard rated applications



- Main valve shall manufactured in accordance with AS/NZS 2845.1.
- Main valve shall be constructed from ductile iron and FBE coated to AS/NZS 4158.
- All internals shall be constructed from stainless steel and to have pressure rating of PN16 and a temperature rating of 60°C.
- Main valve body shall not form part of the wetted check valve sealing area or mechanism.
- All internal parts and elastomers are to be accessible through a top entry point of the main valve to allow inline maintenance. Valve connection shall be flanged to AS 4087 or roll grooved to AS 2368.
- Valve shall also be fitted with test points with BSPT threads to allow testing to AS/NZS 2845.3.

Neither Emerson, Emerson Automation Solutions, nor any of their affiliated entities assumes responsibility for the selection, use or maintenance of any product. Responsibility for proper selection, use, and maintenance of any product remains solely with the purchaser and end user.

ValvCheQ is a mark owned by one of the companies in the Emerson Automation Solutions business unit of Emerson Electric Co. Emerson Automation Solutions, Emerson and the Emerson logo are trademarks and service marks of Emerson Electric Co. All other marks are the property of their respective owners.

The contents of this publication are presented for informational purposes only, and while every effort has been made to ensure their accuracy, they are not to be construed as warranties or guarantees, express or implied, regarding the products or services described herein or their use or applicability. All sales are governed by our terms and conditions, which are available upon request. We reserve the right to modify or improve the designs or specifications of such products at any time without notice.

Emerson.com/FinalControl