

CliniMix® 2000 Lead Safe™ 3/4" Throstatic Mixing Valve

Product Code: 201.70.02.00

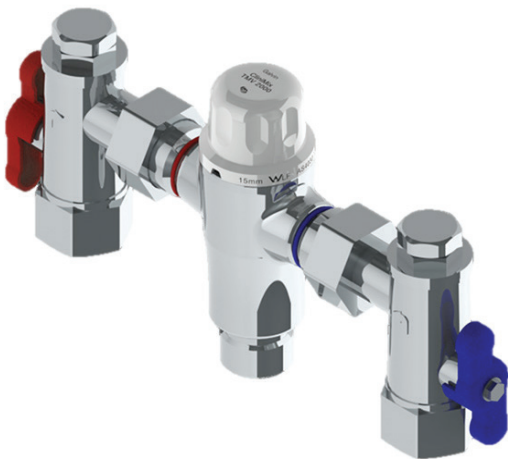

Installation

The CliniMix® 2000 Throstatic Mixing Valve with Integrated Inlet Fittings is designed to comply with AS4032.1 *Throstatic Mixing Valves and NSW Health Department* requirements. In addition to these instructions, the valve must be installed subject to the requirements of the relevant regulatory authorities.

- Check the site conditions** (temperature, pressure, etc.) against the valve specifications shown in Figure 1. Any discrepancies must be rectified prior to valve installation.
 - If there is a risk that the hot water supply temperature exceeds 90°C, a suitable temperature limiting valve must be fitted upstream of the inlet fitting.
 - If there is a risk that the dynamic inlet pressures exceed 600 kPa, a suitable pressure reducing valve must be fitted upstream of the inlet fitting.
 - It is recommended that the inlet pressures are balanced to within $\pm 10\%$ of each other for optimal performance.
- Flush the system** thoroughly before fitting the valve. It is critical that all debris is flushed from the pipework prior to valve installation. Debris and particulate contamination are the most common causes of valve failures.
- Ensure the installation allows **sufficient room for service and maintenance** procedures. Figure 2 shows the physical dimensions of the valve and fittings.
- Attach the supplied Integrated Inlet Fittings** to the valve using the sealing washer to provide a face seal.
 - AS3500 requires that all throstatic mixing valves are installed with isolating valves, line strainers, and non-return valves on the hot and cold supply lines. The supplied inlet fittings ensure this requirement is met. If the valve is to be used without the included inlet fittings, ensure that the relevant devices are installed as specified by the standard. Figure 3 shows the position of each device
 - Install the valve using the 3/4" Female fittings on the inlets and the 1" Male fittings on the outlet.
 - The valve and fittings must not be subject to excessive heat during the installation.

Figure 1 - Throstatic Mixing Valve Specifications

Factory Set Outlet Temperature:	43 +/- 2°C
Outlet Temperature Range:	35 - 50°C ¹
Hot Supply Temperature:	55 - 90°C
Cold Supply Temperature:	5 - 30°C
Hot to Mix Temp Differential:	Min 10°C
Cold to Mix Temp Differential:	Min 5°C
Static Supply Pressure:	Max 1600kPa
Dynamic Inlet Pressure:	20 - 600kPa
Recommended Supply Pressure Variation (Hot:Cold or Cold:Hot):	$\pm 10\%^2$
Supply Pressure Loss Ratio:	Max 10:1
Flow Rate to Ensure Stable Operation:	Min 4L/min

Notes:

- AS4032.1 - 2005: approved adjustment range 38 - 50°C
 - For optimal performance it is recommended that the hot and cold water supply pressures be balanced to within $\pm 10\%$. Excessive variation in supply pressures may cause changes in outlet temperature.
- Notwithstanding the above, compliance with AS3500 must be maintained.

Flow Rate

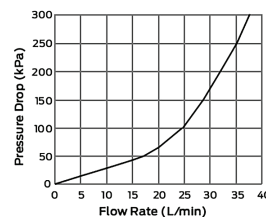

Figure 2 - Physical Dimensions

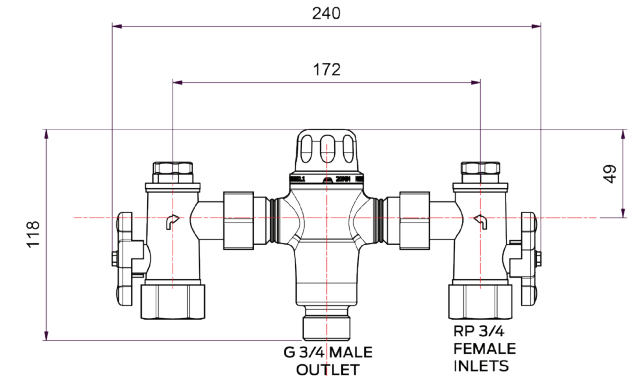
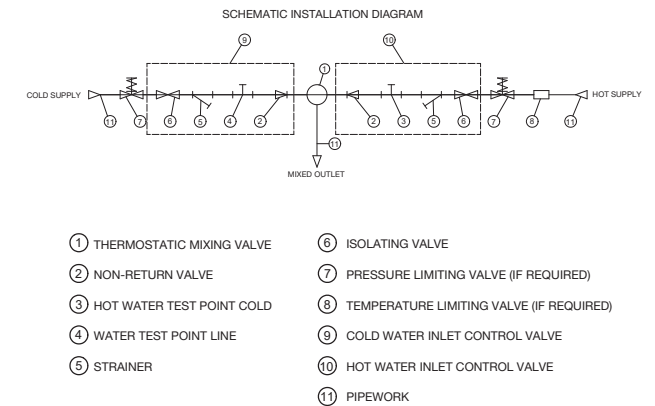

Figure 3 - Installation Schematic



Commissioning of the Valve

Upon completion of the installation, the valve should be tested and commissioned as per the procedure outlined below or as specified by the local authority. The entire procedure should be read through thoroughly prior to the commissioning of the valve. A calibrated digital thermometer having rapid response time with maximum temperature hold, small flat bladed screwdriver and the adjusting key (supplied with the CliniMix® 2000 TMV) will be required to check and set the outlet mixed temperature of the valve.

- Ensure all outlets that will be serviced by the valve have adequate warning signs posted to ensure that no outlet is used during commissioning.
- Open the cold supply line to the valve, and then open the hot supply line, ensuring there are no leaks.
- Open the outlet that is serviced by the shortest length of pipe work between the mixing valve and outlet fixture.
- Ensure the hot and cold water supplies are stable and within the temperature specifications.
- Allow the mixed outlet to flow for at least 60 seconds** to allow the temperature to stabilise before taking a temperature reading at the outlet with a digital thermometer. The flow rate should be at least 4L/min. The flow rate can be checked with the aid of a known size container and a stopwatch. The temperature should be taken at the closest outlet served by the throstatic mixing valve.
- If the outlet temperature requires adjustment the following steps are required;

Temperature Adjustment

- Using a small flat bladed screwdriver, pry the protective cover off the valves (Figure 4).
- Fit the supplied key over the adjusting spindle (Figure 4).
 - To **increase** the mixed outlet temperature, rotate the spindle **anti-clockwise**.
 - To **decrease** the mixed outlet temperature, rotate the spindle **clockwise**.
- Allow the mixed outlet temperature to stabilize for 60 seconds and once again take a temperature reading. Repeat the procedure until the desired temperature has been reached.
- Push the top cover firmly on to the top of the valve until it snaps back into place.
- Check that the outlet temperature is stable over the full range of flow rates and that the flow rate is adequate for the application.
- Close the outlet.
- The mixing valve is now set and locked.

Figure 4 - Increasing and Decreasing the Mixed Water Temperature

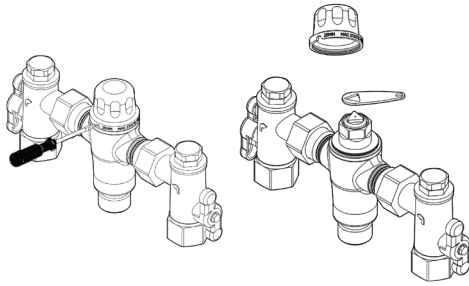

Shut Down Test

- Now that the mixing valve has been set and locked it is necessary to perform a shutdown check. Allow the mixed water temperature to stabilise and note the outlet temperature. While holding a digital thermometer in the outlet flow, quickly isolate the cold water supply to the valve. The outlet should quickly cease to flow. As a rule of thumb the volume should be less than 0.2L following the isolation. Restore the cold water supply and after the mixed water temperature has stabilised, record the outlet temperature and ensure it has remained within specification.
- Repeat the above test, except this time quickly isolate the hot water supply to the valve. The outlet flow should quickly slow to a trickle. As a rule of thumb the trickle should typically be less than 0.4L following the isolation. Restore the hot water supply and after the mixed water temperature has stabilised, record the outlet temperature and ensure it has remained within specification.
- Ensure that all details of the Commissioning Service and Maintenance Report are completed.
- The valve is now commissioned and can be used within the technical limits of operation.

Maintenance and Service Requirements

The following testing and maintenance procedures must be carried out on the valve at intervals not exceeding 12 months:

Strainer cleanliness:

- Isolate the hot and cold supplies to the mixing valve by closing the inlet ball valves.
- Remove the inlet fitting strainer cap with a suitable spanner and then remove the mesh strainer, as shown in Figure 5 below.
- The strainers should be cleaned with a dilute water solution of suitable descaling solvent (such as CLR), checked for physical damage and then thoroughly rinsed with clean water.
- The strainers can then be re-installed into the valve, and the top cover replaced and tightened to a maximum torque of 15Nm into the inlet valve bodies. 4

Figure 5 - Servicing the Inlet Fittings

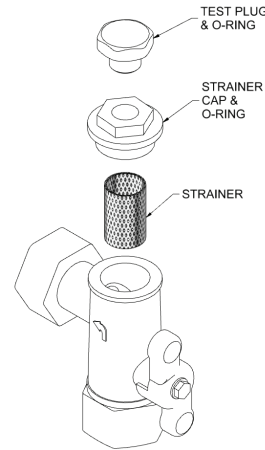

Non-return valve operation:

- Isolate the cold water supply by closing the cold inlet fitting ball valve.
- Remove the cold inlet fitting test point cap with a suitable spanner.
- Check for leakage; after the initial pressure is released, water should not flow out of the strainer cap hole. If water continues flowing out, replace the cap, then replace the non-return valve on the cold inlet fitting and restart the test. If water does not flow out, continue to the next step.
- Remove the adjustment cover with a flat bladed screwdriver. See Figure 4.
- Using the adjustment spanner and method described in *Temperature Adjustment*, turn the spindle one full revolution clockwise, then two full revolutions anti clockwise. Then turn the spindle one full revolution clockwise to return it to the starting position. At no time should water flow out of the inlet fitting strainer cap hole. If water flows out, replace the cap, then replace the non-return valve on the cold inlet fitting and restart the test. If water does not flow out, the non-return valve is operating correctly.
- Replace the test point cap and open the cold inlet fitting ball valve.
- Isolate the hot water supply by closing the hot inlet fitting ball valve.
- Remove the hot inlet fitting test point cap with a suitable spanner.
- Check for leakage; after the initial pressure is released, water should not flow out of the strainer cap hole. If water continues flowing out, replace the cap, then replace the non-return valve on the hot inlet fitting and restart the test. If water does not flow out, continue to the next step.
- Using the adjustment spanner, turn the spindle one full revolution clockwise and then two full revolutions anti-clockwise. Then turn the spindle on full revolution clockwise to return it to the starting position. At no time should water flow out of the inlet fitting strainer cap hole. If water flows out, replace the cap, then replace the non-return valve on the hot inlet fitting and restart the test. If water does not flow out, the hot inlet fitting non-return valve is operating correctly.
- Replace the test point cap and open the hot inlet fitting ball valve.
- Leave the adjustment cover off for access to the temperature adjustment spindle for the next test.

Measure the discharge temperature at the nearest outlet to the valve. Use the procedure described in *Commissioning of Valve*. Measure both at a low and high flow rate. Adjust if necessary and then replace the adjustment cover.

Cold water shut-off operation. Use the procedure described in *Commissioning of Valve*.

Hot water shut-off operation. Use the procedure described in *Commissioning of Valve*.

The results of the maintenance and service inspection must be recorded on the Commissioning, Service and Maintenance Report (back page).

O-Rings and Thermostatic Element/Piston Assembly MANDATORY 5 YEAR SERVICE

At intervals not exceeding 5 years, the piston O-Ring and thermostatic element/piston assembly must be replaced and lubricated. Lubricant must be potable water approved silicon-based grease (supplied with the spare parts kit). Procedure:

- Isolate the hot and cold supplies by closing the inlet ball valves. Vent the outlet pipework at the closest fixture to drain.
- Pry off the plastic cover using a small flat bladed screwdriver or similar.
- Remove the brass cap assembly with a suitable spanner.
- Remove the element/piston assembly.
- Remove the piston O-Ring. Care must be taken to ensure the internal surfaces of the valve body are not damaged.
- Dispose of plastic cover, brass cap assembly, element/piston assembly and piston O-Ring.
- Replace both O-Rings with the parts provided in the spare parts kit (both O-Rings are the same size). Ensure the new O-Rings are clean and lightly greased with the lubricant provided.
- Insert the new element/piston assembly taking great care not to damage the external surfaces of the piston. Refit the cap assembly to the body and tighten to a maximum torque of 10Nm.
- Clean the isolator strainers as shown on page 1. If needed, the 5 Year kit contains new strainers.
- Fully recommission the valve. Fit the provided plastic cover.

Galvin Engineering Pty Ltd.

Within Australia: 1300 514 074 | Outside Australia: +61 (0)8 9338 2344

sales@galvinengineering.com.au www.galvinengineering.com.au

ABN: 78 008 719 382

Revision 1.2, 20 March 2024

Fault Finding

Fault / Symptom

Cause

Rectification

<ul style="list-style-type: none"> The desired mixed water temperature cannot be obtained or the valve is difficult to set 	<ul style="list-style-type: none"> Hot and cold supplies are fitted to the wrong connections Valve contains debris Strainers contain debris Non-return devices are damaged 	<ul style="list-style-type: none"> Refit the valve with Hot/Cold supplies fitted to the correct connections Clean valve ensuring debris is removed and components are not damaged Clean strainers ensuring debris is removed Check non-return devices are not jammed. Clean if necessary
<ul style="list-style-type: none"> The valve will not shut down 	<ul style="list-style-type: none"> The hot to mix temperature differential is not high enough Sealing seat is damaged or fouled by debris 	<ul style="list-style-type: none"> Raise hot water temperature Replace piston o-ring Clean seat using suitable descaling solution
<ul style="list-style-type: none"> Mix temperature is unstable 	<ul style="list-style-type: none"> Debris is fouling valve Flow rate below 4L/min Strainers are fouled Systems may be fluctuating outside valve parameters 	<ul style="list-style-type: none"> Clean the valve ensuring that all debris is removed and components are not damaged Rectify any pressure deterioration Clean strainers Check system pressure, install pressure control valves to ensure inlet conditions are within specification
<ul style="list-style-type: none"> Mix temperature changing over time 	<ul style="list-style-type: none"> Inlet conditions (pressures or temperatures) are fluctuating Strainers contain debris 	<ul style="list-style-type: none"> Install suitable pressure control valves to ensure inlet conditions are within specification Clean strainers ensuring debris is removed
<ul style="list-style-type: none"> Either full hot or cold flowing from outlet fixture 	<ul style="list-style-type: none"> Valve is incorrectly set Hot/Cold water has migrated to other inlet 	<ul style="list-style-type: none"> Adjust mix temperature between 35 - 50°C as required Replace faulty non-return valves
<ul style="list-style-type: none"> No flow from the valve outlet 	<ul style="list-style-type: none"> Hot or cold water failure Strainers are fouled 	<ul style="list-style-type: none"> Valve functioning correctly. Restore inlet supplies and check mix temperature Clean strainers
<ul style="list-style-type: none"> Flow rate reduced or fluctuating 	<ul style="list-style-type: none"> Valve or inlet fittings fouled by debris Dynamic inlet pressures are not within recommended limits 	<ul style="list-style-type: none"> Check valve and inlet fittings for blockages Ensure the dynamic inlet pressures are nominally balanced to within +/- 10%
<ul style="list-style-type: none"> Mixed water temperature too hot or cold 	<ul style="list-style-type: none"> Valve has been tampered with Valve incorrectly set Inlet temperatures are not within specified limits 	<ul style="list-style-type: none"> Readjust valve to required set temperature Ensure inlet temperatures are within required limits
<ul style="list-style-type: none"> Hot water flows into the cold water system or vice versa 	<ul style="list-style-type: none"> Non-return valves faulty 	<ul style="list-style-type: none"> Replace non-return valves
<ul style="list-style-type: none"> Valve is noisy 	<ul style="list-style-type: none"> Water velocity above velocity requirements of AS3500 	<ul style="list-style-type: none"> Reduce water velocity
<ul style="list-style-type: none"> Temperature adjuster difficult to move 	<ul style="list-style-type: none"> Adjustment at maximum mix temperature stops. Valve piston over set. 	<ul style="list-style-type: none"> Mixed water is at maximum temperature no higher mix. Wind adjuster out until set temperature required is achieved.

